

INSTRUCTION MANUAL
HYDRAULIC TABLE TRUCK

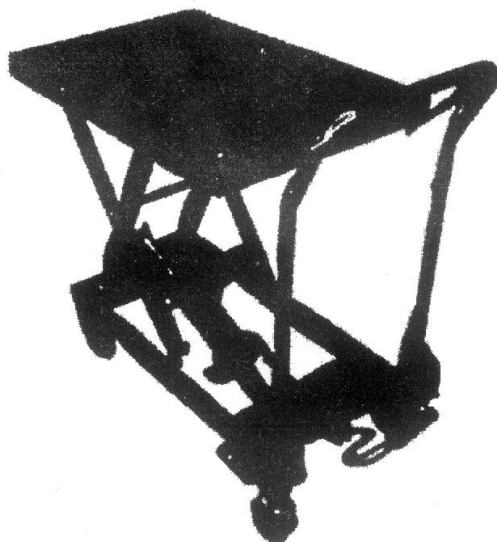

Model: TF 30/50/50B

TF 30/50/50B Hydraulic Table Truck

(Cable Release 2)

I. Use & applicable range

It is a convertible vehicle using for lifting and transporting in workshop, warehouse and wharf, etc.

II. Basic Data:

Model	TF 30	TF 50	TF50B
Load Capacity	300kgs	500kgs	500kgs
Lift Height	900mm	900mm	900mm
Lowest Height	280/380mm	290/385mm	295/390mm
Table Dimensions	825×500×50mm	825×500×55mm	1600×800×55mm
Packing Dimensions	900×520×300/400mm	900×520×300/400mm	1685×830×310/410mm
Net Weight	76kgs	84kgs	135kgs

III. Installing

1. Install the handle (#27) on the frame seat (#12), and fix them by two M12 bolts.
2. Insert the foot pedal rod (#58) into the hole of the foot pedal holder (#54), and fix them by M8 bolt.
3. Insert the brake thread (#31) into the press bolt (#42), and fix them by M8 nut.

IV. Using

1. Test the cart before using it. Firstly step the foot pedal rod to lift the table to the max height, and then release the limit oil valve to check whether the cart is ok.
2. Please fix the cart and to brake the wheel before loading.
3. Adjust the table's height by step the foot pedal lift up and down to load or unloading in its rated loading.
4. When lower the table, draw up the handle.

V. Warning

- (1) Operate strictly according to the instruction manual.
- (2) Do not use the cart on slop.
- (3) Do not allow people to sit or ride on the cart.
- (4) Keep feet and hand away from under the lowering table. Suggest to wear safety shoes during operation.
- (5) Do not transport the loads during the raising process.
- (6) Do not random regulate the safety valve.
- (7) The maintenance is to be performed by the professional person
- (8) Failure to operate the cart will cause the damage to the person health or property loss.
- (9) The cart must used in the rated capacity, it is not permit to load the heavy goods that the rated capacity of the cart.

TF30/50 Hand-hydraulic Table Truck

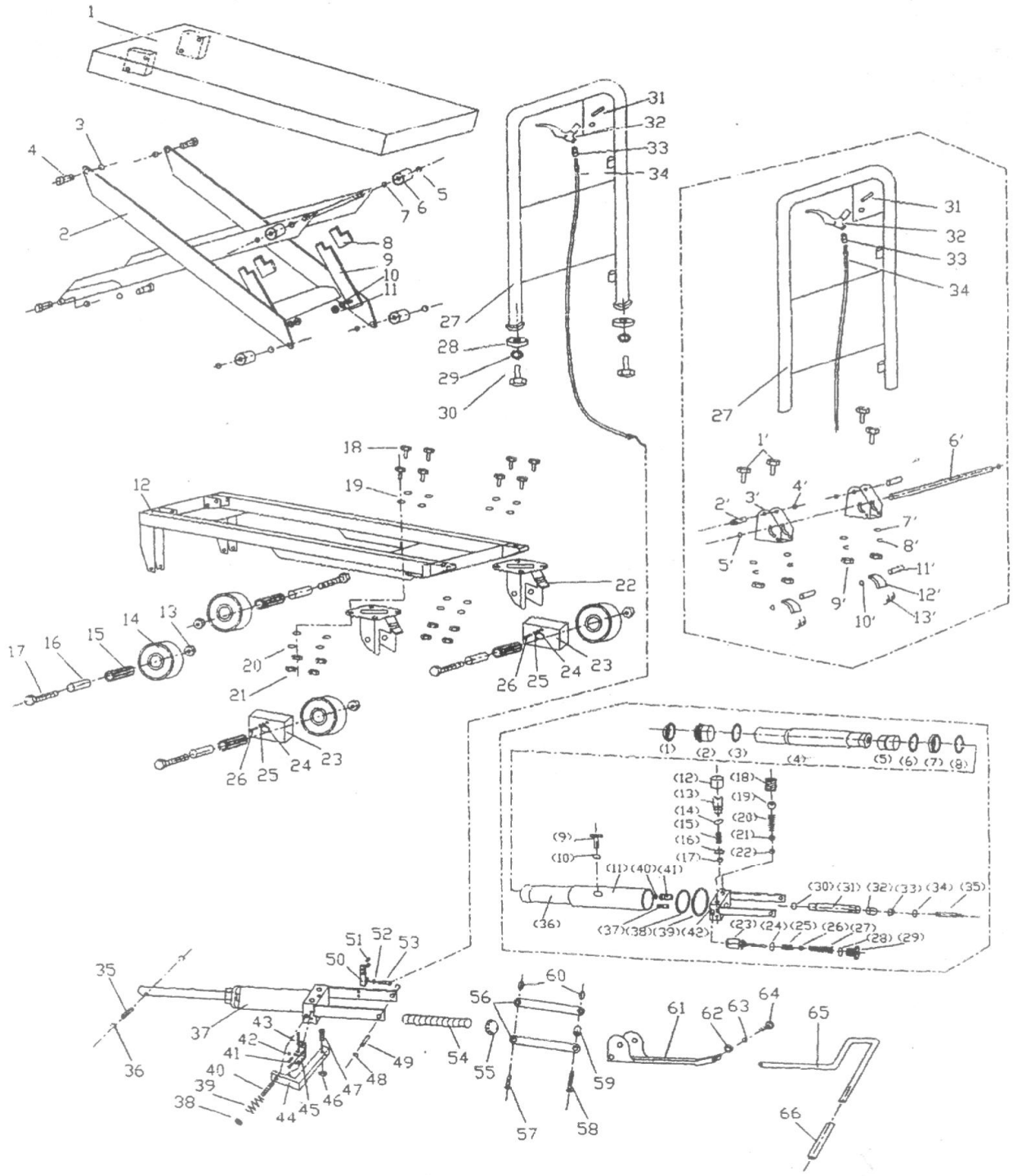

**TF30/50/50B Hydraulic Table Truck
(Cable Release 2)**

No.	Description	Q'ty	No.	Description	Q'ty	No.	Description	Q'ty
1	Table	1	43	Spring Pin	1	[5]	Piston	1
2	Link Assembly	1	44	Draw Board	1	[6]	O-ring	1
3	C-ring	4	45	Support Holder	1	[7]	Oil Seal	1
4	Shaft	4	46	Hex Cap Nut	1	[8]	C-ring	1
5	C-ring	4	47	Screw	1	[9]	Hex Cap Plug	1
6	Roller Guide	4	48	C-ring	2	[10]	O-ring	1
7	Flat Washer	4	49	Shaft	1	[11]	Outer Cylinder Body	1
8	Rubber Cover	2*	50	Support Rod	1	[12]	Adjust Pressure Cover	1
9	Support Rod	2*	51	Hex Cap Screw	2	[13]	Adjust Pressure Screw	1
10	Flat Washer	2*	52	Hex Cap Nut	1	[14]	O-ring	1
11	Hex Cap Nut	2*	53	Copper Joint Slice	1	[15]	Adjust Pressure Spring	1
12	Frame Seat	1	54	Big Spring	1	[16]	Spring Seat	1
13	Set Nut	4	55	Spring Seat	1	[17]	Steel Ball	1
14	Wheel	4	56	Link Slice	2	[18]	Hex Cap Bolt	1
15	Roller Guide	4	57	Shaft	1	[19]	Steel Ball	1
16	Roller Shaft	4	58	Shaft	1	[20]	Taper Spring	1
17	Hex Cap Bolt	4	59	Separate Cover	1	[21]	Steel Ball	1
18	Hex Cap Bolt	8	60	Lock Pin	2	[22]	Steel Ball	1
19	Flat Washer	8	61	Foot Pedal Holder	1	[23]	Top Rod	1
20	Spring Washer	8	62	Flat Washer	1	[24]	O-ring	1
21	Hex Cap Nut	8	63	Spring Washer	1	[25]	Spring	1
22	Swivel Wheel Holder	2	64	Hex Cap Screw	1	[26]	Steel Ball	1
23	Protect Cover	2*	65	Foot Pedal Rod	1	[27]	Spring	1
24	Flat Washer	2*	66	Foot Pedal Cover	1	[28]	O-ring	1
25	Spring Washer	2*	1'	Hex Cap Bolt	4	[29]	Hex Cap Plug	1
26	Semicircle Screw	2*	2'	Shaft	2	[30]	O-ring	1
27	Handle	1	3'	Folded Holder	2	[31]	Pump Cylinder	1
28	Flat Washer	2	4'	Spring C-ring	4	[32]	O-ring	1
29	Spring Washer	2	5'	Spring C-ring	2	[33]	Dust Cover	1
30	Hex Cap Bolt	2	6'	Brake Rod	1	[34]	Oil Seal	1
31	Spring Pin	1	7'	Flat Washer	4	[35]	Small Lift Piston	1
32	Brake Handle	1	8'	Spring Washer	4	[36]	Inter Cylinder Body	1
33	Set Postion Cover	1	9'	Hex Cap Nut	4	[37]	Filter	1
34	Brake Thread	1	10'	Spring C-ring	2	[38]	Washer (1)	1
35	Shaft	1	11'	Shaft	2	[39]	Washer (2)	1
36	C-ring	2	12'	Cam	2	[40]	O-ring	1
37	Cylinder	1	13'	Turn Spring	2	[41]	Lowering Valve	1
38	Hex Cap Nut	1				[42]	Valve	1
39	Spring	1	[1]	Dust Cover	1			
40	Set Screw	1	[2]	Top Nut	1			
41	Hex Cap Screw	2	[3]	O-ring	1			
42	Spring Washer	2	[4]	Lift Piston	1			
						Remark: the parts with "*" is only CE type use.		